

ASSEM

Für diese technischen Unterlagen behalten wir uns alle Rechte nach DIN ISO 16016 vor				Maßstab: 1:1		
				Maße ohne Toleranzangabe nur zur Information		
				Datum	Name	
				Bear.	16.07.2019	KORP
				Gepr.		
				Norm		
				DIS:	115422,ZDR,DRW,00	
				 Dr. Hahn [®] TÜRBÄNDER. MADE IN GERMANY.		
				Benennung:		NICHT Freigegeben!
				Zeichnungsnummer:		Blatt
				Rollenband AT		1
				Alutech W62-W72		3
				R751_AT00		
In.	Änderung	Datum	Name	Urspr.:	Ers.f.	Modell-Nr. R751_AT00

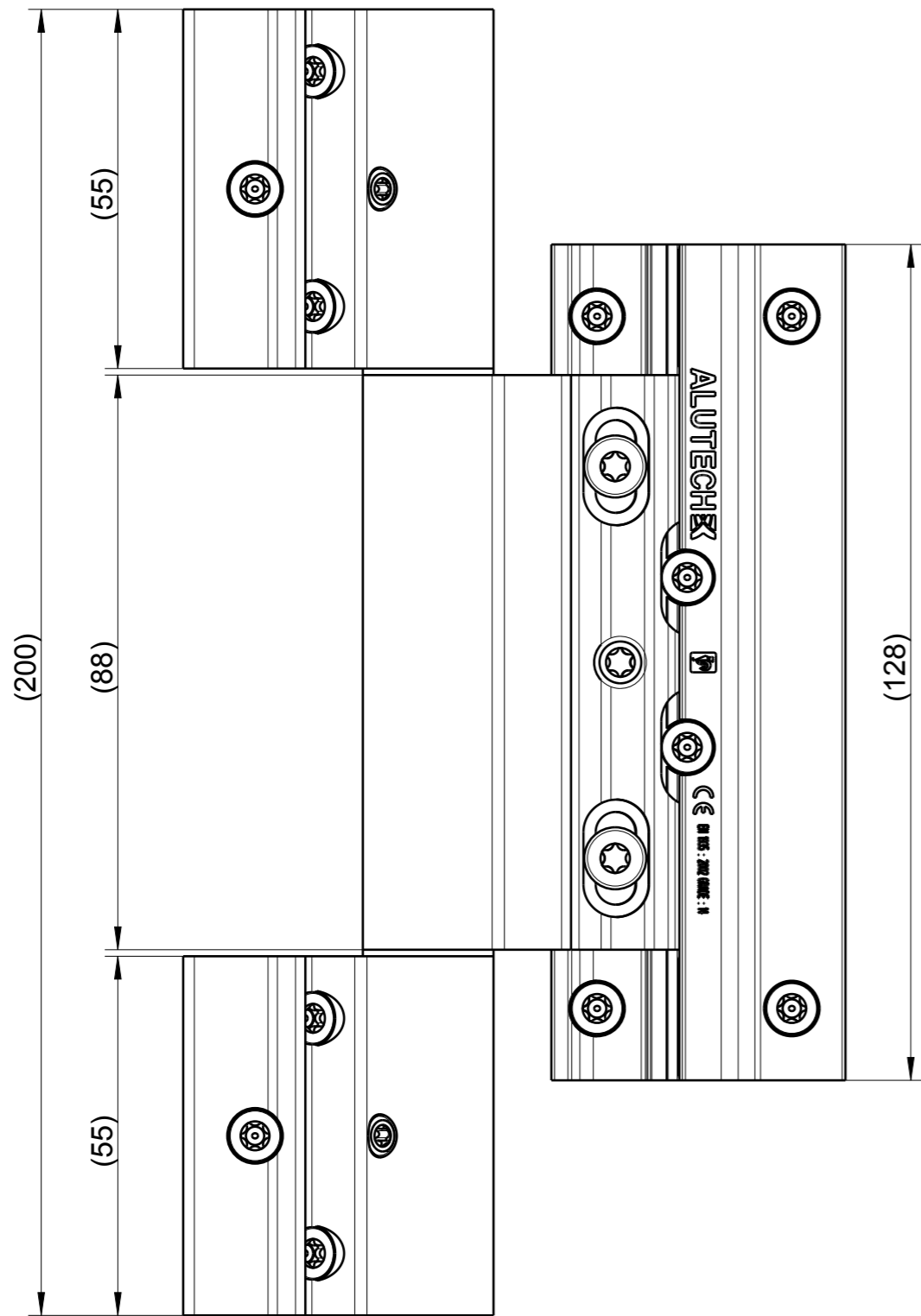

Pos	Menge	Benennung	Sachnummer
1	2	RBT AT 6 / 13,5	R700F0009
2	2	Lagerbuchse FBT exzentrisch schwarz	R600K0001
3	1	FBT Einheit komplett Rollenband AT	R700B0007
4	1	Lagerbolzen	R600E0007
5	2	Gewindestift M6x5-TX15 A4	R400E0010
6	12	Bef.-Schraube RB-AT 4,8x16	R700E0000

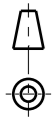
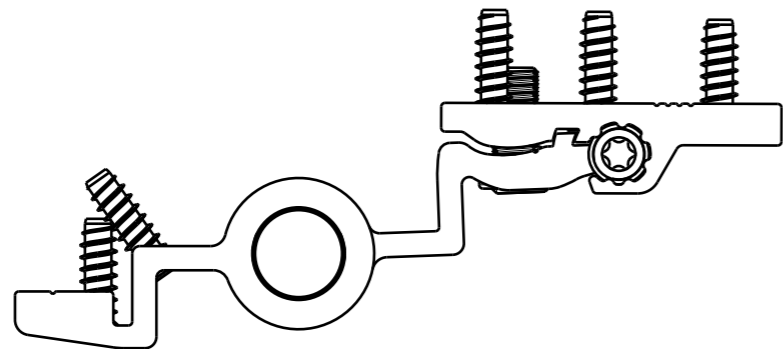
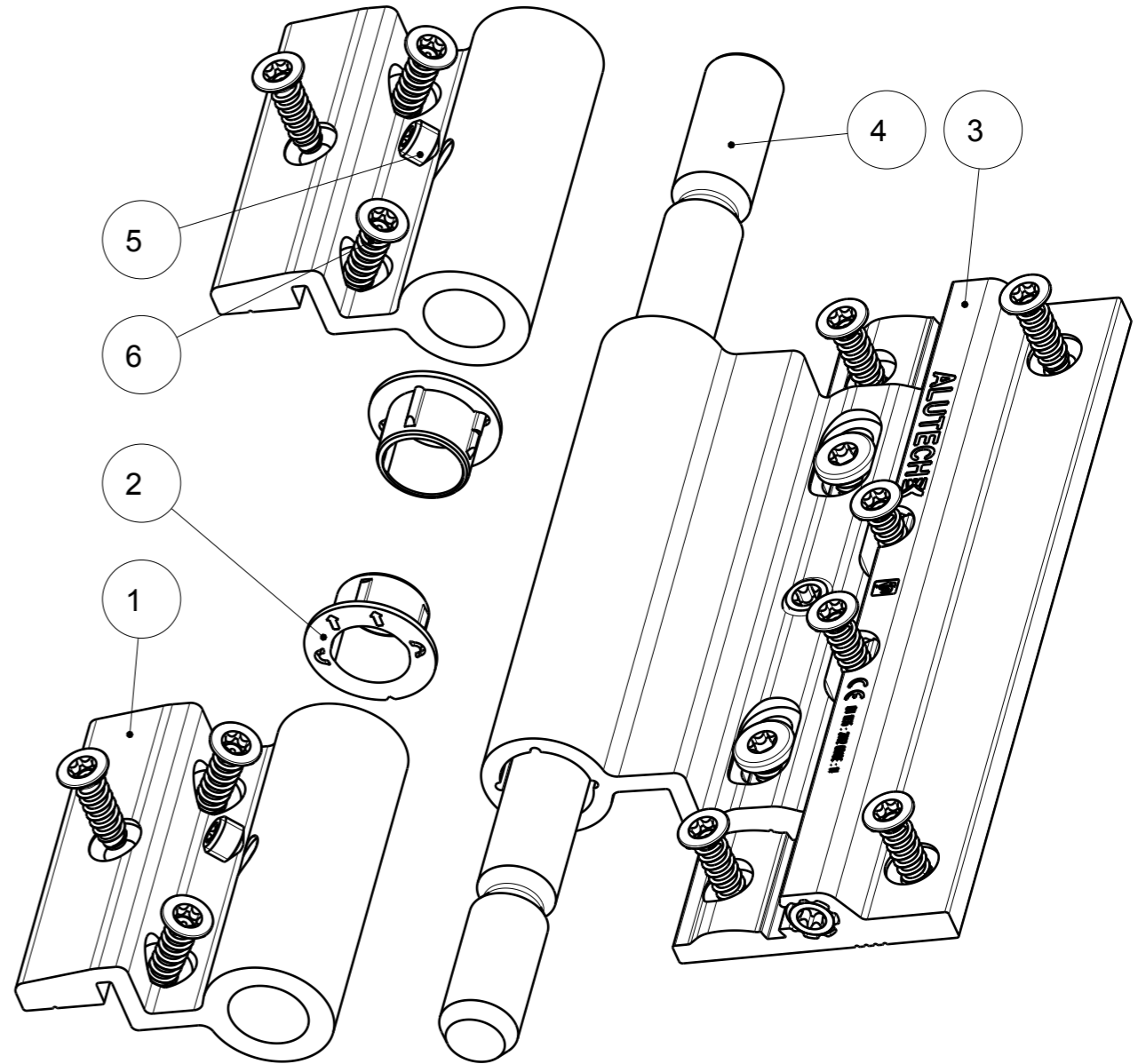

ASSEM

Für diese technischen Unterlagen behalten wir uns alle Rechte nach DIN ISO 16016 vor				Maßstab: 1:1	
				Maße ohne Toleranzangabe nur zur Information	
		Datum	Name	Benennung: NICHT Freigegeben!	
		Bear.	16.07.2019	KORP	
		Gep.			
		Norm			
		DIS:	115422_ZDR_DRW_00		
		Dr. Hahn [®]		Zeichnungsnummer:	
		TÜRBÄNDER. MADE IN GERMANY.		R751_AT00	
In.	Änderung	Datum	Name	Urspr.:	Ers.f.
				Modell-Nr. R751_AT00	
				Blatt	
				2	
				3	

Nach innen öffnende Tür 62

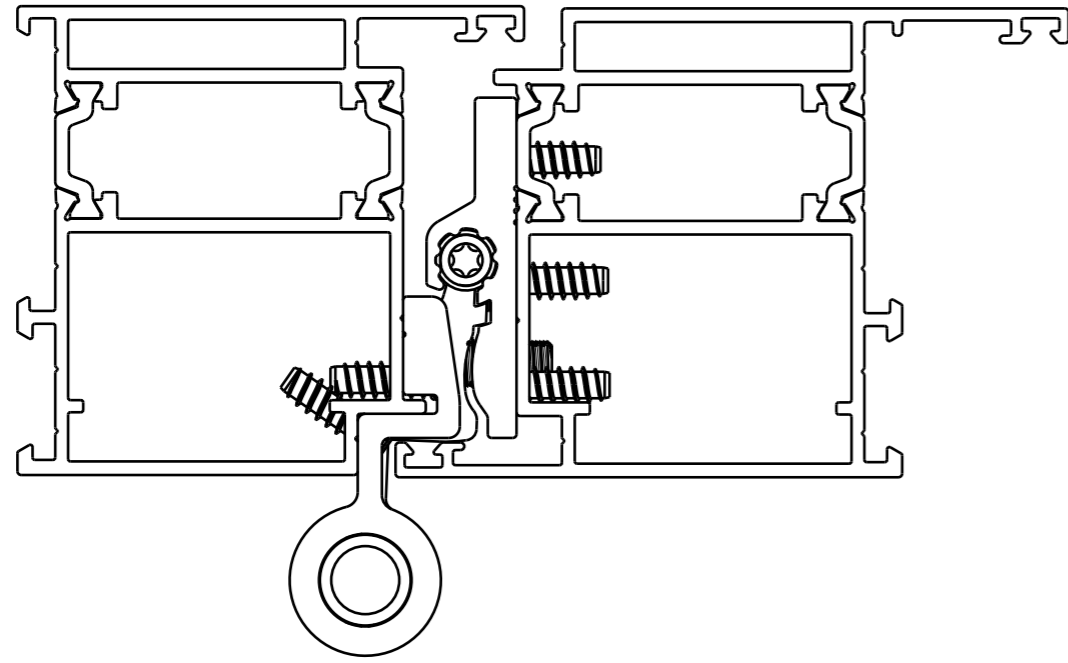

Nach außen öffnende Tür 62

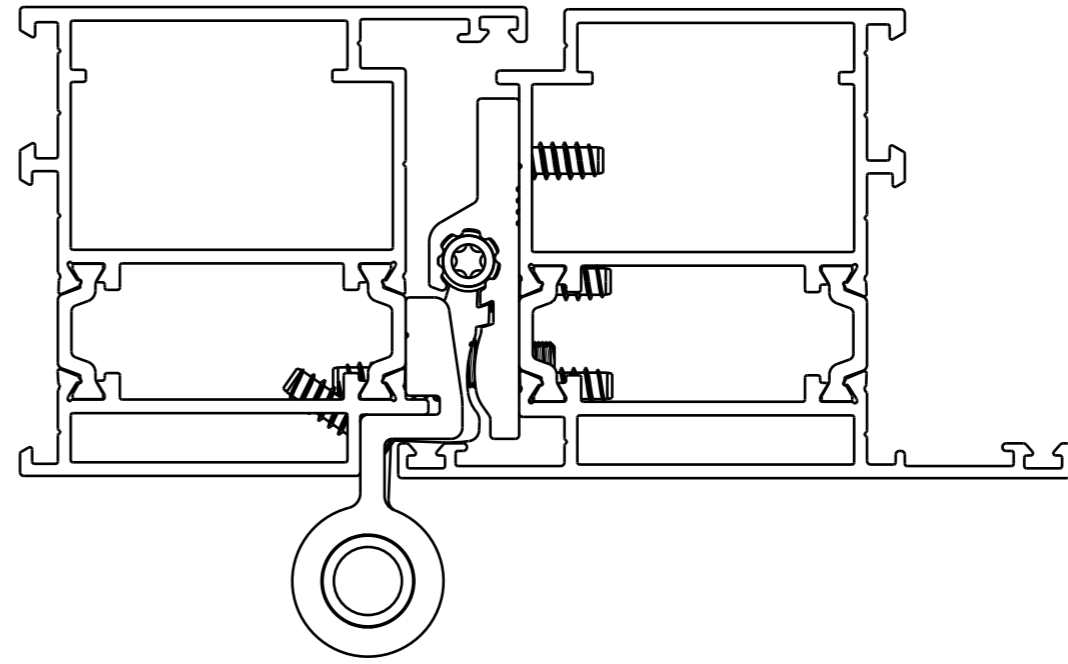

Nach innen öffnende Tür 72

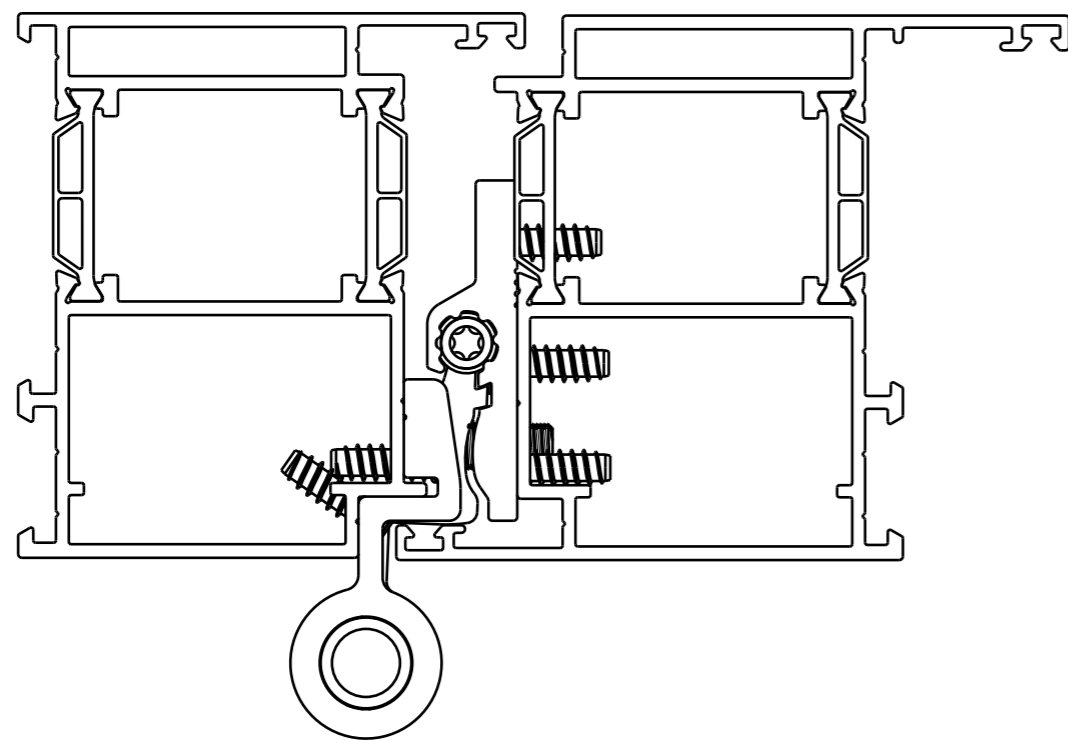

Nach außen öffnende Tür 72

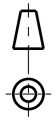
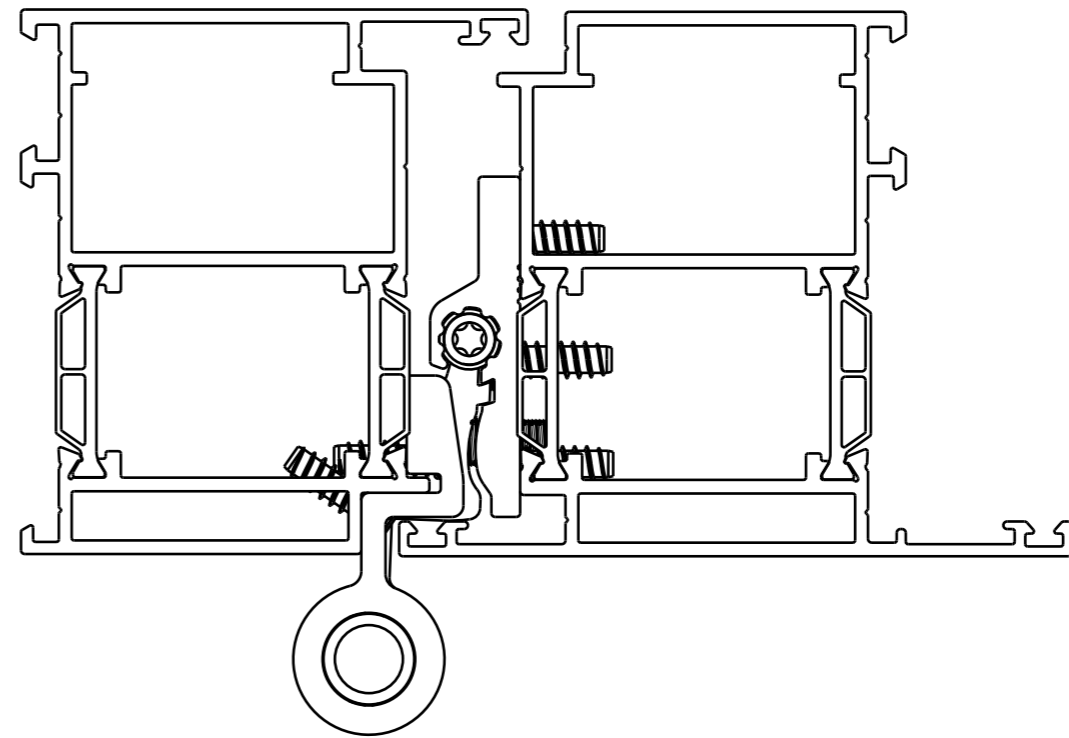

ASSEM

Für diese technischen Unterlagen behalten wir uns alle Rechte nach DIN ISO 16016 vor				Maßstab: 1:1	
				Maße ohne Toleranzangabe nur zur Information	
				Benennung: NICHT Freigegeben!	
		Datum	Name	Rollenband AT Alutech W62-W72	
	Bear.	16.07.2019	KORP		
	Gepr.				
	Norm				
	DIS:	115422,ZDR,DRW,00		Zeichnungsnummer:	
				R751_AT00	
In.	Änderung	Datum	Name	Urspr.:	Blatt
					3
					3
				Ers.f.	Modell-Nr. R751_AT00

